

157  
Copy 2 of 3

RG&E Report No. B-07-223

ROCHESTER GAS AND ELECTRIC CORPORATION

1982 Fish Impingement Data Report

Russell Power Station

Data Collected and Report  
Prepared by  
Rochester Gas & Electric  
Corporation  
Nancy J. Edwards  
February, 1985

## TABLE OF CONTENTS

	<u>Page</u>
List of Tables	iii
List of Figures	iv
I. Introduction	1
II. Materials	2
A. Study Site	2
B. Detailed Study	3
C. Daily Biomass Collection	5
III. Results	6

LIST OF TABLES

<u>Table No.</u>		<u>Page</u>
1	1982 Russell Station Impingement Study, List of Fish Species Collected	10
2 through 39	1982 Russell Station Impingement Tables	11-29
40 through 51	1982 Daily Biomass Collection Tables	30-41

## LIST OF FIGURES

<u>Figure</u>		<u>Page</u>
1	Russell Station Site Location	7
2	Russell Station Intake Structure	8
3	Russell Station, Plan View of Screenhouse, Forebay and Traveling Water Screens	9

I. INTRODUCTION

As part of Rochester Gas and Electric Corporation's Environmental Monitoring Program, impingement studies were conducted at RG&E's Russell Power Station in order to gather information regarding the type and number of fish species which are impinged, and the environmental conditions associated with such impingement. This report describes the methods used in obtaining and analyzing these fish, as well as the basic results of the 1982 impingement studies at Russell Power Station.

## II. MATERIALS AND METHODS

### A. Study Site

Rochester Gas and Electric Corporation's Russell Power Station is located on Lake Ontario's southern shore, northwest of the City of Rochester, New York (Figure 1) and approximately 2.4 km (1.5 mi.) west of the mouth of the Genesee River. The plant intake system is shown in Figure 2 and Figure 3, which depict the intake structure and the greenhouse facilities, respectively. This system consists of an 18.5M x 7.9M (61 ft. x 26 ft.) intake structure located offshore 1144M (3774 ft.) in about 9.1M (30 ft.) of water (lake elevation = 246 ft.). The intake velocity is about 0.8 fps through the trash bars on the structure. With a velocity of 7.0 fps the water moves shoreward through the intake tunnel entering the forebay of the greenhouse, where it is passed through four vertically traveling screens. The screens are operated sequentially, each being on for 15-20 minutes, with approximately 20 minutes separating the end of one screen wash and the start of the next. This washwater, carrying all collected screened material, travels down a trough and is collected in a sluiceway basket (Figure 3). It is from this point that impingement samples are removed.

## B. Detailed Studies

The detailed impingement studies during 1982 were scheduled for one 24-hour period per week. Sample periods began at 0900 the first day and ended at 0900 the following day. All fish washed off the vertical traveling screens were collected in a wire mesh basket made to fit in the sluiceway to filter all screen washwater (Figure 3). This basket was lifted and the contents removed at the end of the 24-hour sampling period. The date listed on the data tables indicates the day sampling was initiated.

Collected fish were separated, normally identified to species, counted, and measured for length and weight. In cases where large numbers of a species were collected, all individuals were counted and a subsample of approximately 20 specimens were individually measured for length and weight. A batch weight of the remainder of that sample was then taken in order to get a total and average weight for that species. Within each species the fish collected were further divided into adults and juveniles, when this distinction was readily apparent.

Identification of all species collected was done according to Scott and Crossman (1973). Verification of species in question were performed by independent, qualified fisheries personnel.

Along with each sampling, records of plant circulating cooling water flow, intake temperature, discharge temperature, air temperature, wind speed and direction, and general weather conditions were kept and have been presented with each sample date in the data table. Results are presented in terms of both number collected each day as well as numbers per unit volume of cooling water, in this case numbers/million gallons/day. Presenting findings in terms of numbers per unit volume simplifies comparisons between dates and/or stations.

### C. Daily Biomass Collection

The Daily Biomass Collection is a more qualitative 24-hour "impingement" sample taken each day (Tables 40 through 51). The sluiceway basket is emptied each morning and a total weight of everything collected is taken. Based on a macroscopic observation of the sample, the percentage of trash vs. fish is estimated. Trash in this instance represents all items excepting fish (e.g. rocks, seaweed, debris, crayfish, etc.). Using these percentages, one can then calculate from the total biomass collected the approximate kilograms of fish present. Although definitely not an exacting, quantitative sample, nor a detailed assessment of daily impingement, these collections were instituted in an attempt to provide some information concerning impingement on non-study days. Such information is expected to be useful in determining representativeness of scheduled sampling and environmental effects, among other concerns.

### III. RESULTS

During 1982 a total of 38 24-hour detailed sampling periods were conducted (Tables 2 through 39). Overall, a total of 16 species were identified, in addition, one other group was identified to the family level (Table 1). Daily biomass collections were taken on 251 days out of the 327 remaining days of the year (Tables 40 through 51). Combined detailed sampling and daily biomass collections represent impingement sampling conducted for 79% of the days in 1982.

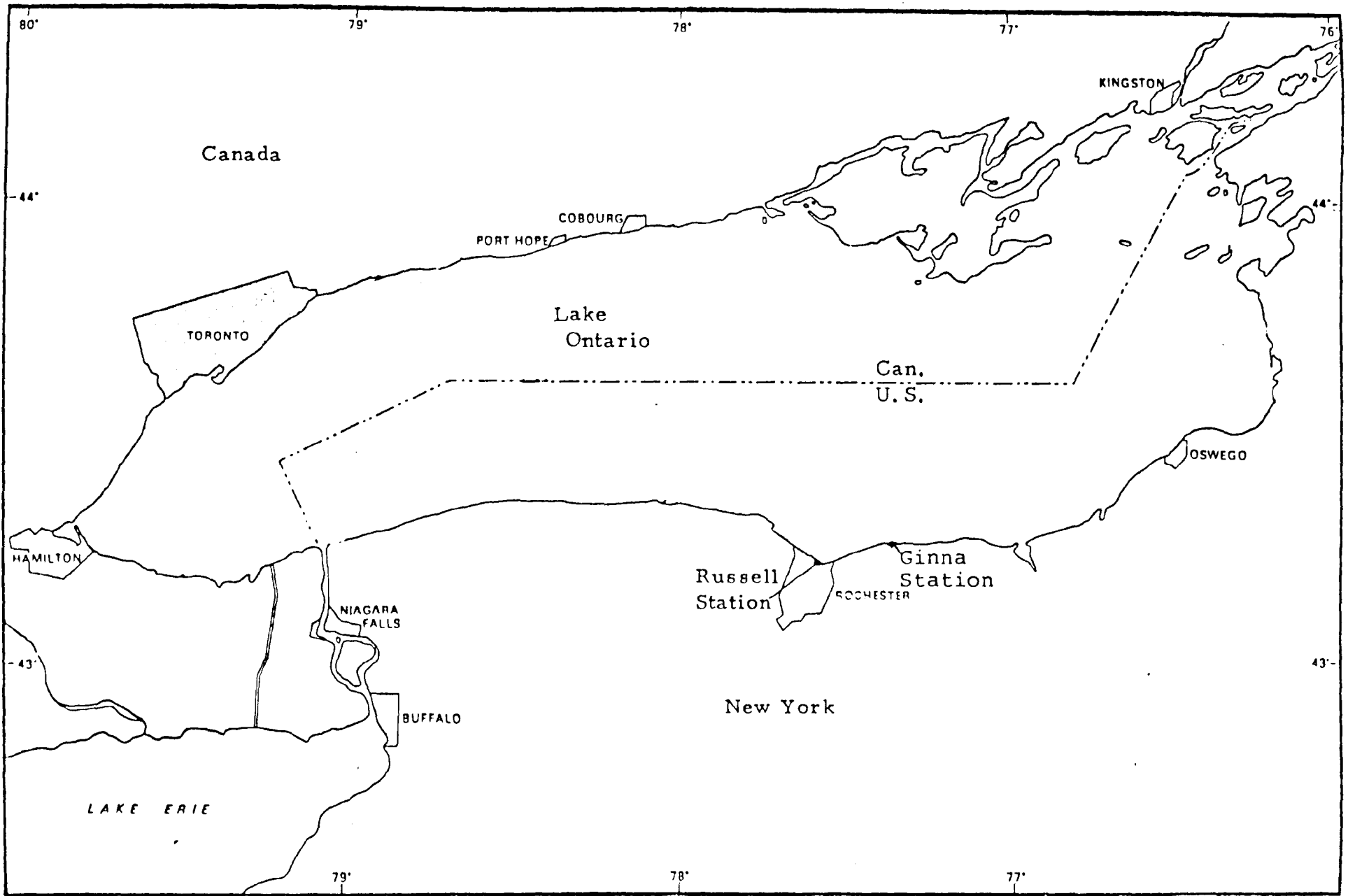

FIGURE 1  
RUSSELL STATION  
SITE LOCATION

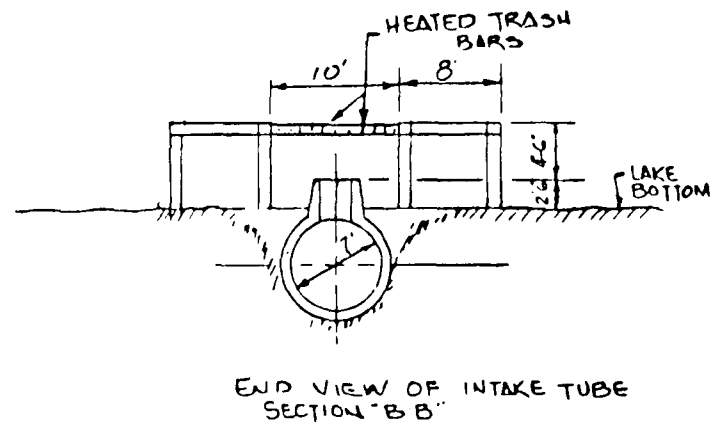
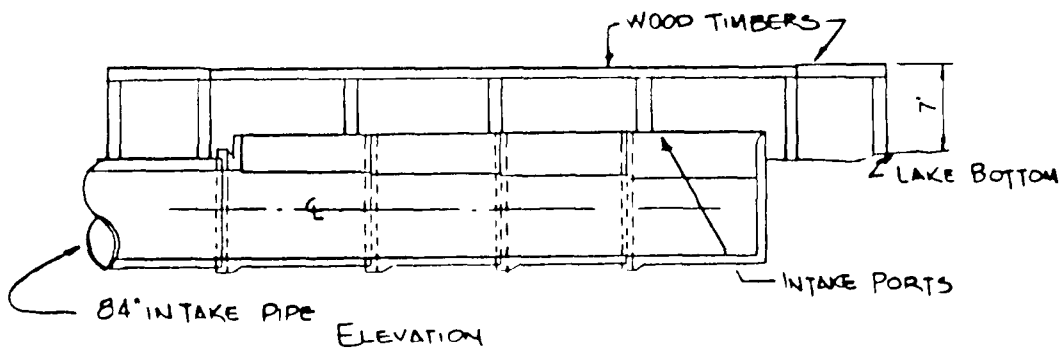
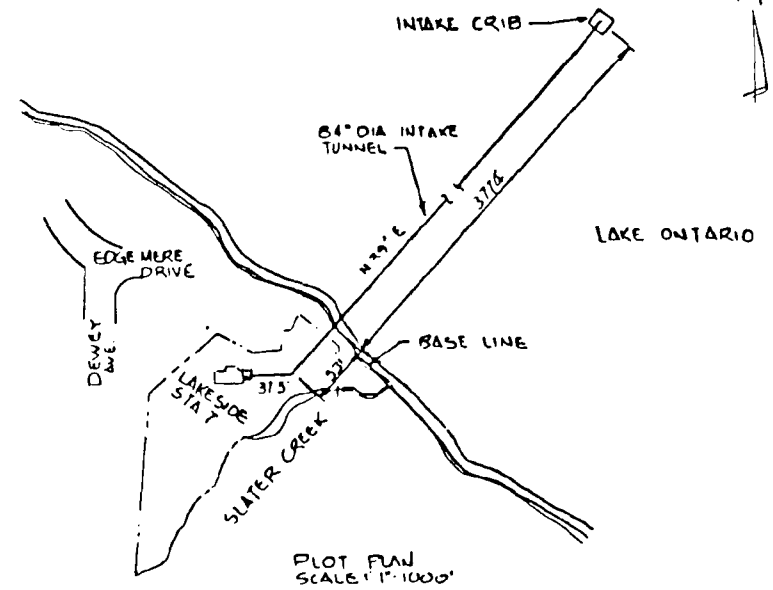
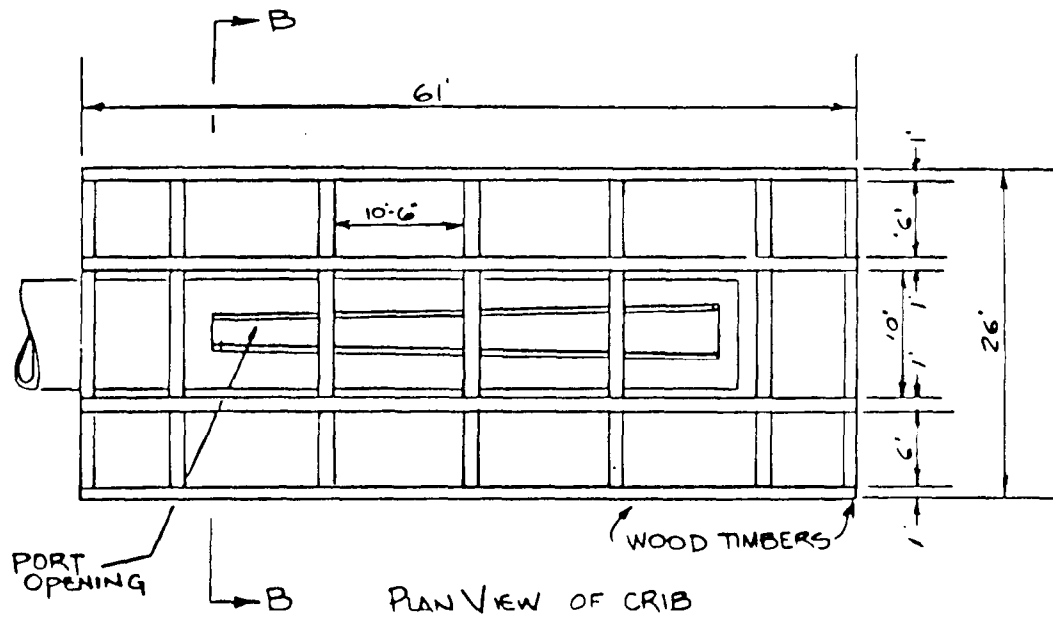

FIGURE 2  
RUSSELL STATION  
INTAKE STRUCTURE

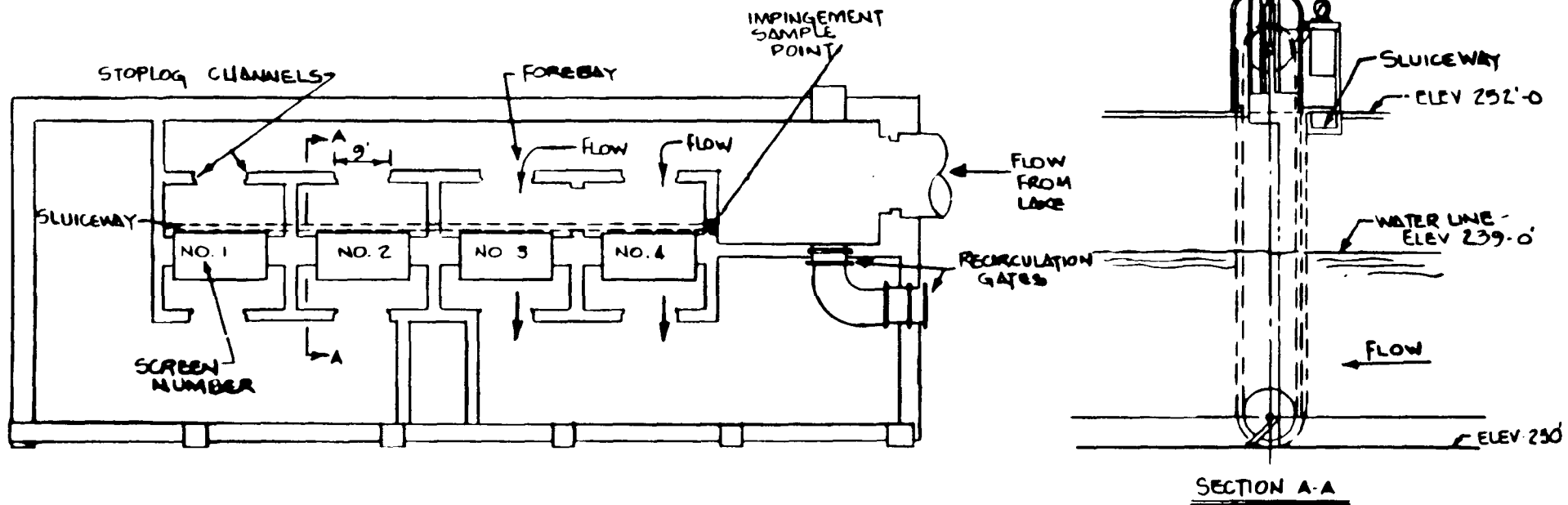

FIGURE 3  
RUSSELL STATION

PLAN VIEW OF SCREENHOUSE  
FOREBAY & TRAVELLING WATER SCREEN

TABLE 1

1982 Russell Power Station Impingement Program  
List of Fish Species Collected

	<u>SCIENTIFIC NAME</u>	<u>COMMON NAME</u>
Anguillidae	<u>Anguilla</u> <u>restrata</u>	American Eel
Clupeidae	<u>Alosa</u> <u>pseudoharengus</u> <u>Dorosoma</u> <u>cepedianum</u>	Alewife Gizzard Shad
Salmonidae	<u>Salmo</u> <u>gairdneri</u>	Rainbow Trout
Osmeridae	<u>Osmerus</u> <u>mordax</u>	Rainbow Smelt
Cyprinidae	<u>Notropis</u> <u>atherinoides</u> <u>Notropis</u> <u>hudsonius</u>	Emerald Shiner Spottail Shiner
Catostomidae	<u>Catostomus</u> <u>commersoni</u>	White Sucker
Percopsidae	<u>Percopsis</u> <u>omiscomaycus</u>	Trout Perch
Percichthyidae	<u>Morone</u> <u>americana</u>	White Perch
Centrarchidae	<u>Ambloplites</u> <u>rupestris</u> <u>Micropterus</u> <u>salmoides</u> Unid. Centrarchidae	Rock Bass Largemouth Bass
Percidae	<u>Stizostedion</u> <u>vitreum</u> <u>vitreum</u> <u>Perca</u> <u>flavescans</u>	Walleye Yellow Perch
Cottidae	<u>Cottus</u> <u>bairdi</u> <u>Cottus</u> <u>cognatus</u>	Mottled Sculpin Slimy Sculpin

TABLE 2

Russell Power Plant  
1982 Impingement Program

Date: 01/18/82  
 Plant Flow (MGD): 123.91  
 Discharge Temp. ( $^{\circ}$ C): 12.22  
 Intake Temp. ( $^{\circ}$ C): 1.11  
 Wind Speed (knots): 10.34  
 Wind Direction: SW  
 Air Temp. ( $^{\circ}$ C): -16.67

<u>Species</u>	<u>Total Number</u>	<u>Avg. Length (cm)</u>	<u>Avg. Weight (gm)</u>	<u>F/MG</u>
Rainbow Smelt Juv.	11	6.8	1.7	0.08877
Rainbow Smelt	17	17.0	29.8	0.13720
Emerald Shiner	1	9.2	4.0	0.00807
Spottail Shiner	4	9.3	6.5	0.03228
White Sucker	1	24.7	38.0	0.00807
Unid. Centrarchidae	1	18.0	-	0.00807
Total	35		593.3*	0.28246

TABLE 3

Russell Power Plant  
1982 Impingement Program

Date: 01/28/82  
 Plant Flow (MGD): 123.91  
 Discharge Temp. ( $^{\circ}$ C): 11.67  
 Intake Temp. ( $^{\circ}$ C): 1.67  
 Wind Speed (knots): 16.60  
 Wind Direction: W  
 Air Temp. ( $^{\circ}$ C): -0.56

<u>Species</u>	<u>Total Number</u>	<u>Avg. Length (cm)</u>	<u>Avg. Weight (gm)</u>	<u>F/MG</u>
Alewife	1	15.4	30.0	0.00807
Rainbow Smelt Juv.	2	6.4	16.5	0.01614
Rainbow Smelt	7	16.1	28.0	0.05649
Emerald Shiner	1	9.2	7.0	0.00807
Spottail Shiner	9	9.5	14.1	0.07263
White Sucker	3	32.8**	430.0**	0.02421
White Perch	1	8.7	10.0	0.00807
Rock Bass	4	14.6	101.8	0.03228
Total	28		2100.1***	0.22597

\* Total weight of all impinged organisms except the unid. Centrarchidae

\*\* Avg. Length and Avg. Weight based on 2 measured White Suckers

\*\*\*Total weight of all impinged organisms

TABLE 4

Russell Power Plant  
1982 Impingement Program

Date: 02/11/82  
 Plant Flow (MGD): 119.40  
 Discharge Temp. ( $^{\circ}$ C): 13.33  
 Intake Temp. ( $^{\circ}$ C): 0.56  
 Wind Speed (knots): 11.65  
 Wind Direction: W  
 Air Temp. ( $^{\circ}$ C): -11.67

<u>Species</u>	<u>Total Number</u>	<u>Avg. Length (cm)</u>	<u>Avg. Weight (gm)</u>	<u>F/MG</u>
Rainbow Smelt	2	16.4	21.0	0.01675
Spottail Shiner	3	10.3	16.3	0.02513
White Perch	9	22.9	258.4	0.07538
Rock Bass	3	14.2	75.3	0.02513
Yellow Perch	1	20.5	118.0	0.00836
Total	18		2760.4*	0.15075

TABLE 5

Russell Power Plant  
1982 Impingement Program

Date: 02/25/82  
 Plant Flow (MGD): 127.70  
 Discharge Temp. ( $^{\circ}$ C): 12.22  
 Intake Temp. ( $^{\circ}$ C): 1.11  
 Wind Speed (knots): 12.52  
 Wind Direction: NW  
 Air Temp. ( $^{\circ}$ C): -10.56

<u>Species</u>	<u>Total Number</u>	<u>Avg. Length (cm)</u>	<u>Avg. Weight (gm)</u>	<u>F/MG</u>
Rainbow Smelt	8	15.7	27.6	0.06265
Spottail Shiner	11	11.1	12.1	0.08614
White Perch	9	10.3	17.9	0.07048
Rock Bass	1	14.4	80.0	0.00783
Mottled Sculpin	1	6.0	6.0	0.00783
Total	30		601.0*	0.23493

\*Total weight of all impinged organisms

TABLE 6

Russell Power Plant  
1982 Impingement Program

Date: 03/04/82  
 Plant Flow (MGD): 132.19  
 Discharge Temp. (°C): 10.00  
 Intake Temp. (°C): 0.00  
 Wind Speed (knots): 11.04  
 Wind Direction: S  
 Air Temp. (°C): -3.33

<u>Species</u>	<u>Total Number</u>	<u>Avg. Length (cm)</u>	<u>Avg. Weight (gm)</u>	<u>F/MG</u>
Rainbow Smelt	2	14.7	17.0	0.01513
Spottail Shiner	12	10.5	12.8	0.09078
Rock Bass	<u>3</u>	17.0	<u>115.3</u>	<u>0.02269</u>
Total	17		533.5*	0.12860

TABLE 7

Russell Power Plant  
1982 Impingement Program

Date: 03/11/82  
 Plant Flow (MGD): 152.28  
 Discharge Temp. (°C): 15.56  
 Intake Temp. (°C): 1.67  
 Wind Speed (knots): 10.17  
 Wind Direction: SW  
 Air Temp. (°C): 7.22

<u>Species</u>	<u>Total Number</u>	<u>Avg. Length (cm)</u>	<u>Avg. Weight (gm)</u>	<u>F/MG</u>
Rainbow Smelt	1	14.9	21.0	0.00657
White Sucker	3	32.5	446.7	0.01970
Rock Bass	<u>2</u>	18.5	<u>123.0</u>	<u>0.01313</u>
Total	6		1607.1*	0.03940

\*Total weight of all impinged organisms

TABLE 8

Russell Power Plant  
1982 Impingement Program

Date: 03/26/82  
 Plant Flow (MGD): 152.06  
 Discharge Temp. (°C): 15.00  
 Intake Temp. (°C): 2.78  
 Wind Speed (knots): 17.65  
 Wind Direction: W  
 Air Temp. (°C): -2.22

<u>Species</u>	<u>Total Number</u>	<u>Avg. Length (cm)</u>	<u>Avg. Weight (gm)</u>	<u>F/MG</u>
Alewife	20	17.4	33.1	0.13153
Rainbow Smelt	92	15.7**	28.4**	0.60502
Emerald Shiner	4	9.2	3.8	0.02631
Spottail Shiner	27	11.1	16.2	0.17756
White Sucker	1	22.0	125.0	0.00658
Yellow Perch	1	20.7	115.0	0.00658
White Perch	20	10.6	18.4	0.13153
Slimy Sculpin	1	6.6	2.0	0.00658
Total	166		4337.4*	1.09167

TABLE 9

Russell Power Plant  
1982 Impingement Program

Date: 04/01/82  
 Plant Flow (MGD): 152.30  
 Discharge Temp. (°C): 13.89  
 Intake Temp. (°C): 3.33  
 Wind Speed (knots): 20.34  
 Wind Direction: NW  
 Air Temp. (°C): 2.78

<u>Species</u>	<u>Total Number</u>	<u>Avg. Length (cm)</u>	<u>Avg. Weight (gm)</u>	<u>F/MG</u>
Alewife	2	16.7	29.5	0.01313
Rainbow Smelt	60	14.3	21.9	0.39396
Emerald Shiner	2	9.7	7.0	0.01313
Spottail Shiner	7	10.8	15.0	0.04596
White Perch	3	8.8	9.0	0.01970
Total	74		1519.0*	0.48588

\* Total weight of all impinged organisms

\*\*Avg. length and avg. weight based on subsample of 20 individuals

TABLE 10

Russell Power Plant  
1982 Impingement Program

Date: 04/13/82  
 Plant Flow (MGD): 155.90  
 Discharge Temp. ( $^{\circ}$ C): 14.44  
 Intake Temp. ( $^{\circ}$ C): 6.11  
 Wind Speed (knots): 16.34  
 Wind Direction: W  
 Air Temp. ( $^{\circ}$ C): 8.33

<u>Species</u>	<u>Total Number</u>	<u>Avg. Length (cm)</u>	<u>Avg. Weight (gm)</u>	<u>F/MG</u>
White Sucker	2	39.0	679.0	0.01283
Rainbow Smelt	<u>30</u>	16.1	<u>23.2</u>	<u>0.19243</u>
Total	32		2054.0*	0.20526

TABLE 11

Russell Power Plant  
1982 Impingement Program

Date: 04/24/82  
 Plant Flow (MGD): 155.60  
 Discharge Temp. ( $^{\circ}$ C): 15.00  
 Intake Temp. ( $^{\circ}$ C): 5.00  
 Wind Speed (knots): 15.13  
 Wind Direction: SW  
 Air Temp. ( $^{\circ}$ C): 15.00

<u>Species</u>	<u>Total Number</u>	<u>Avg. Length (cm)</u>	<u>Avg. Weight (gm)</u>	<u>F/MG</u>
Alewife	1	17.0	34.0	0.00643
Rainbow Smelt	<u>13</u>	14.6	<u>24.0</u>	<u>0.08355</u>
Total	14		346.0*	0.08997

\*Total weight of all impinged organisms

TABLE 12

Russell Power Plant  
1982 Impingement Program

Date: 05/07/82  
 Plant Flow (MGD): 157.54  
 Discharge Temp. (°C): 17.22  
 Intake Temp. (°C): 6.67  
 Wind Speed (knots): 7.91  
 Wind Direction: NE  
 Air Temp. (°C): 14.44

<u>Species</u>	<u>Total Number</u>	<u>Avg. Length (cm)</u>	<u>Avg. Weight (gm)</u>	<u>F/MG</u>
Alewife	4	17.8	31.8	0.02539
Rainbow Smelt	2	14.8	19.5	0.01270
Rainbow Trout	<u>1</u>	-	<u>-</u>	<u>0.00635</u>
Total	7		166.2*	0.04443

TABLE 13

Russell Power Plant  
1982 Impingement Program

Date: 05/17/82  
 Plant Flow (MGD): 157.54  
 Discharge Temp. (°C): 18.89  
 Intake Temp. (°C): 8.33  
 Wind Speed (knots): 6.60  
 Wind Direction: NE  
 Air Temp. (°C): 15.56

<u>Species</u>	<u>Total Number</u>	<u>Avg. Length (cm)</u>	<u>Avg. Weight (gm)</u>	<u>F/MG</u>
Alewife	2	17.7	32.5	0.01270
Rainbow Smelt	<u>1</u>	16.1	<u>18.0</u>	<u>0.00635</u>
Total	3		83.0**	0.01904

\* Total weight of all impinged organisms except the Rainbow Trout  
 \*\*Total weight of all impinged organisms

TABLE 14

Russell Power Plant  
1982 Impingement Program

Date: 05/24/82  
 Plant Flow (MGD): 157.18  
 Discharge Temp. (°C): 17.78  
 Intake Temp. (°C): 6.67  
 Wind Speed (knots): 10.60  
 Wind Direction: N  
 Air Temp. (°C): 16.67

<u>Species</u>	<u>Total Number</u>	<u>Avg. Length (cm)</u>	<u>Avg. Weight (gm)</u>	<u>F/MG</u>
Alewife	33	14.5**	22.4**	0.20995
Rainbow Smelt	4	14.4	20.8	0.02545
White Sucker	1	26.0	186.0	0.00636
White Perch	1	22.0	180.0	0.00636
Rock Bass	1	19.9	162.0	0.00636
Yellow Perch	2	26.5	287.0	0.01272
Slimy Sculpin	2	6.0	4.5	0.01272
Total	44		1933.4*	0.27993

TABLE 15

Russell Power Plant  
1982 Impingement Program

Date: 05/28/82  
 Plant Flow (MGD): 155.59  
 Discharge Temp. (°C): 15.56  
 Intake Temp. (°C): 6.11  
 Wind Speed (knots): 10.34  
 Wind Direction: SE  
 Air Temp. (°C): 20.00

<u>Species</u>	<u>Total Number</u>	<u>Avg. Length (cm)</u>	<u>Avg. Weight (gm)</u>	<u>F/MG</u>
Alewife	123	15.9**	28.3**	0.79054
Rainbow Smelt Juv.	1	7.5	2.0	0.00643
Rainbow Smelt	3	16.7	27.3	0.01928
Total	127		3564.8*	0.81625

\* Total weight of all impinged organisms

\*\*Avg. length and avg. weight based on subsample of 20 individuals

TABLE 16

Russell Power Plant  
1982 Impingement Program

Date: 05/30/82  
 Plant Flow (MGD): 118.22  
 Discharge Temp. ( $^{\circ}$ C): 13.89  
 Intake Temp. ( $^{\circ}$ C): 4.44  
 Wind Speed (knots): 5.73  
 Wind Direction: N  
 Air Temp. ( $^{\circ}$ C): 21.67

<u>Species</u>	<u>Total Number</u>	<u>Avg. Length (cm)</u>	<u>Avg. Weight (gm)</u>	<u>F/MG</u>
Alewife	51	15.5**	28.0**	0.43140
Rainbow Smelt	6	15.1	21.3	0.05075
Rock Bass	1	15.9	82.0	0.00846
Total	58		1637.8*	0.49061

TABLE 17

Russell Power Plant  
1982 Impingement Program

Date: 06/07/82  
 Plant Flow (MGD): 118.22  
 Discharge Temp. ( $^{\circ}$ C): 16.67  
 Intake Temp. ( $^{\circ}$ C): 6.11  
 Wind Speed (knots): 6.17  
 Wind Direction: NE  
 Air Temp. ( $^{\circ}$ C): 17.78

<u>Species</u>	<u>Total Number</u>	<u>Avg. Length (cm)</u>	<u>Avg. Weight (gm)</u>	<u>F/MG</u>
Alewife Juv.	1	9.5	2.0	0.00846
Alewife	46	15.3**	21.2**	0.38911
Rainbow Smelt	4	15.0	20.5	0.03384
Trout Perch	1	11.8	14.0	0.00846
White Perch	1	21.2	64.0	0.00846
Largemouth Bass	1	30.2	458.0	0.00846
Unid. Centrarchidae	1	73.0	2625.0	0.00846
Total	55		4220.2*	0.46523

\* Total weight of all impinged organisms

\*\*Avg. length and avg. weight based on subsample of 20 individuals

TABLE 18

Russell Power Plant  
1982 Impingement Program

Date: 06/14/82  
 Plant Flow (MGD): 118.22  
 Discharge Temp. (°C): 14.44  
 Intake Temp. (°C): 5.56  
 Wind Speed (knots): 7.73  
 Wind Direction: W  
 Air Temp. (°C): 17.78

<u>Species</u>	<u>Total Number</u>	<u>Avg. Length (cm)</u>	<u>Avg. Weight (gm)</u>	<u>F/MG</u>
Alewife	11	14.4	21.9	0.09305
Rainbow Smelt Juv.	1	7.7	2.0	0.00846
Rainbow Smelt	4	14.9	20.3	0.03384
Yellow Perch	<u>2</u>	27.1	<u>277.0</u>	<u>0.01692</u>
Total	18		878.1*	0.15226

TABLE 19

Russell Power Plant  
1982 Impingement Program

Date: 06/21/82  
 Plant Flow (MGD): 118.22  
 Discharge Temp. (°C): 21.67  
 Intake Temp. (°C): 11.67  
 Wind Speed (knots): 11.91  
 Wind Direction: SW  
 Air Temp. (°C): 16.67

<u>Species</u>	<u>Total Number</u>	<u>Avg. Length (cm)</u>	<u>Avg. Weight (gm)</u>	<u>F/MG</u>
Alewife Juv.	1	8.7	6.0	0.00846
Alewife	15	15.4	25.9	0.12688
Rock Bass	<u>1</u>	22.4	<u>255.0</u>	<u>0.00846</u>
Total	17		649.5*	0.14380

\*Total weight of all impinged organisms

TABLE 20

Russell Power Plant  
1982 Impingement Program

Date: 06/28/82  
 Plant Flow (MGD): 118.22  
 Discharge Temp. (°C): 20.56  
 Intake Temp. (°C): 11.67  
 Wind Speed (knots): 5.21  
 Wind Direction: NE  
 Air Temp. (°C): 21.11

<u>Species</u>	<u>Total Number</u>	<u>Avg. Length (cm)</u>	<u>Avg. Weight (gm)</u>	<u>F/MG</u>
Alewife	62	15.8**	25.0**	0.52445
Rainbow Smelt Juv.	2	9.6	5.0	0.01692
Rainbow Smelt	10	14.7	15.8	0.08459
White Sucker	<u>1</u>	35.4	<u>146.0</u>	<u>0.00846</u>
Total	75		1864.0*	0.63441

TABLE 21

Russell Power Plant  
1982 Impingement Program

Date: 07/12/82  
 Plant Flow (MGD): 126.00  
 Discharge Temp. (°C): 21.67  
 Intake Temp. (°C): 12.22  
 Wind Speed (knots): 13.47  
 Wind Direction: SW  
 Air Temp. (°C): 23.33

<u>Species</u>	<u>Total Number</u>	<u>Avg. Length (cm)</u>	<u>Avg. Weight (gm)</u>	<u>F/MG</u>
Alewife	67	22.4**	28.6**	0.53175
Rainbow Smelt Juv.	23	8.5	2.4	0.18254
Rainbow Smelt	13	14.0	12.9	0.10317
Yellow Perch	<u>2</u>	24.3	<u>191.5</u>	<u>0.01587</u>
Total	105		2522.1*	0.83333

\*Total weight of all impinged organisms

\*\*Avg. length and avg. weight based on subsample of 20 individuals

TABLE 22

Russell Power Plant  
1982 Impingement Program

Date: 07/22/82  
 Plant Flow (MGD): 126.00  
 Discharge Temp. (°C): 32.22  
 Intake Temp. (°C): 21.11  
 Wind Speed (knots): 5.21  
 Wind Direction: N  
 Air Temp. (°C): 21.67

<u>Species</u>	<u>Total Number</u>	<u>Avg. Length (cm)</u>	<u>Avg. Weight (gm)</u>	<u>F/MG</u>
Alewife	155	16.4**	27.4**	1.23016
White Sucker	2	45.9	1033.0	0.01587
Rock Bass	<u>1</u>	20.5	<u>145.0</u>	<u>0.00794</u>
Total	158		6458.0*	1.25397

TABLE 23

Russell Power Plant  
1982 Impingement Program

Date: 07/26/82  
 Plant Flow (MGD): 126.00  
 Discharge Temp. (°C): 32.22  
 Intake Temp. (°C): 20.56  
 Wind Speed (knots): 8.78  
 Wind Direction: NW  
 Air Temp. (°C): 25.00

<u>Species</u>	<u>Total Number</u>	<u>Avg. Length (cm)</u>	<u>Avg. Weight (gm)</u>	<u>F/MG</u>
Alewife	14	16.3	27.1	0.11111
Rock Bass	<u>1</u>	19.0	<u>166.0</u>	<u>0.00794</u>
Total	15		545.4*	0.11905

\* Total weight of all impinged organisms

\*\*Avg. length and avg. weight based on subsample of 20 individuals

TABLE 24

Russell Power Plant  
1982 Impingement Program

Date: 08/09/82  
 Plant Flow (MGD): 126.00  
 Discharge Temp. ( $^{\circ}$ C): 21.11  
 Intake Temp. ( $^{\circ}$ C): 10.56  
 Wind Speed (knots): 9.47  
 Wind Direction: W  
 Air Temp. ( $^{\circ}$ C): 22.78

<u>Species</u>	<u>Total Number</u>	<u>Avg. Length (cm)</u>	<u>Avg. Weight (gm)</u>	<u>F/MG</u>
Alewife	28	15.3	26.0	0.22222
Rainbow Smelt Juv.	10	8.6	3.0	0.07937
Rainbow Smelt	<u>1</u>	13.0	<u>12.0</u>	<u>0.00794</u>
Total	39		770.0*	0.30952

TABLE 25

Russell Power Plant  
1982 Impingement Program

Date: 08/16/82  
 Plant Flow (MGD): 134.06  
 Discharge Temp. ( $^{\circ}$ C): 31.67  
 Intake Temp. ( $^{\circ}$ C): 21.67  
 Wind Speed (knots): 6.34  
 Wind Direction: W  
 Air Temp. ( $^{\circ}$ C): 22.22

<u>Species</u>	<u>Total Number</u>	<u>Avg. Length (cm)</u>	<u>Avg. Weight (gm)</u>	<u>F/MG</u>
Alewife	3	17.0	17.7	0.02238
Rock Bass	<u>3</u>	18.5	<u>147.0</u>	<u>0.02238</u>
Total	6		494.1*	0.04476

\*Total weight of all impinged organisms

TABLE 26

Russell Power Plant  
1982 Impingement Program

Date: 08/23/82  
 Plant Flow (MGD): 120.96  
 Discharge Temp. (°C): \*\*  
 Intake Temp. (°C): \*\*

Wind Speed (knots): 8.60  
 Wind Direction: SW  
 Air Temp. (°C): 20.00

<u>Species</u>	<u>Total Number</u>	<u>Avg. Length (cm)</u>	<u>Avg. Weight (gm)</u>	<u>F/MG</u>
Alewife	<u>2</u>	17.6	<u>21.5</u>	<u>0.01653</u>
Total	2		43.0*	0.01653

TABLE 27

Russell Power Plant  
1982 Impingement Program

Date: 08/30/82  
 Plant Flow (MGD): 71.71  
 Discharge Temp. (°C): 27.78  
 Intake Temp. (°C): 17.78

Wind Speed (knots): 7.91  
 Wind Direction: SW  
 Air Temp. (°C): 19.44

<u>Species</u>	<u>Total Number</u>	<u>Avg. Length (cm)</u>	<u>Avg. Weight (gm)</u>	<u>F/MG</u>
No Fish Impinged				

\* Total weight of all impinged organisms  
 \*\*Not available due to equipment malfunction

TABLE 28

Russell Power Plant  
1982 Impingement Program

Date: 09/07/82  
 Plant Flow (MGD): 119.74  
 Discharge Temp. (°C): 28.33  
 Intake Temp. (°C): 16.67  
 Wind Speed (knots): 9.39  
 Wind Direction: E  
 Air Temp. (°C): 12.78

<u>Species</u>	<u>Total Number</u>	<u>Avg. Length (cm)</u>	<u>Avg. Weight (gm)</u>	<u>F/MG</u>
Alewife	1	18.0	28.0	0.00835
Gizzard Shad	6	15.9	38.0	0.05011
Rainbow Smelt	2	15.2	28.0	0.01670
Spottail Shiner	1	12.0	24.0	0.00835
Trout Perch	5	11.0	15.4	0.04176
White Perch	2	9.0	12.0	0.01670
Rock Bass	3	20.3	188.3	0.02505
Yellow Perch	1	22.7	168.0	0.00835
Total	21		1169.9*	0.17538

TABLE 29

Russell Power Plant  
1982 Impingement Program

Date: 09/13/82  
 Plant Flow (MGL): 119.74  
 Discharge Temp. (°C): 25.56  
 Intake Temp. (°C): 14.44  
 Wind Speed (knots): 6.17  
 Wind Direction: SW  
 Air Temp. (°C): 24.44

<u>Species</u>	<u>Total Number</u>	<u>Avg. Length (cm)</u>	<u>Avg. Weight (gm)</u>	<u>F/MG</u>
Rainbow Smelt Juv.	1	8.3	3.0	0.00835
Rock Bass	2	15.3	97.0	0.01670
Total	3		197.0*	0.02505

\*Total weight of all impinged organisms

TABLE 30

Russell Power Plant  
1982 Impingement Program

Date: 09/30/82  
 Plant Flow (MGD): 117.94                      Wind Speed (knots): 5.47  
 Discharge Temp. (°C): 25.56                  Wind Direction: SW  
 Intake Temp. (°C): 14.44                      Air Temp. (°C): 17.22

<u>Species</u>	<u>Total Number</u>	<u>Avg. Length (cm)</u>	<u>Avg. Weight (gm)</u>	<u>F/MG</u>
Rainbow Smelt Juv.	1	8.7	2.0	0.00848
White Sucker	1	34.2	396.0	0.00848
Rock Bass	1	15.0	75.0	0.00848
Yellow Perch	<u>2</u>	26.3	<u>311.0</u>	<u>0.01696</u>
Total	5		1095.0*	0.04239

TABLE 31

Russell Power Plant  
1982 Impingement Program

Date: 10/03/82  
 Plant Flow (MGD): 117.94                      Wind Speed (knots): 8.78  
 Discharge Temp. (°C): 26.67                  Wind Direction: W  
 Intake Temp. (°C): 13.89                      Air Temp. (°C): 17.22

<u>Species</u>	<u>Total Number</u>	<u>Avg. Length (cm)</u>	<u>Avg. Weight (gm)</u>	<u>F/MG</u>
American Eel	1	50.5	286.0	0.00848
White Sucker	1	38.5	517.0	0.00848
Rock Bass	3	21.1	220.3	0.02544
Walleye	1	37.6	474.0	0.00848
Yellow Perch	<u>3</u>	22.4	<u>190.0</u>	<u>0.02544</u>
Total	9		2507.9*	0.07631

\*Total weight of all impinged organisms

TABLE 32

Russell Power Plant  
1982 Impingement Program

Date: 10/05/82  
 Plant Flow (MGD): 117.94                      Wind Speed (knots): 3.39  
 Discharge Temp. (°C): 25.00                  Wind Direction: N  
 Intake Temp. (°C): 14.44                      Air Temp. (°C): 14.44

<u>Species</u>	<u>Total Number</u>	<u>Avg. Length (cm)</u>	<u>Avg. Weight (gm)</u>	<u>F/MG</u>
White Sucker	1	37.3	836.0	0.00848
Rock Bass	3	20.8	249.0	0.02544
Yellow Perch	<u>1</u>	22.5	<u>176.0</u>	<u>0.00848</u>
Total	5		1759.0*	0.04239

TABLE 33

Russell Power Plant  
1982 Impingement Program

Date: 10/14/82  
 Plant Flow (MGD): 151.85                      Wind Speed (knots): 10.17  
 Discharge Temp. (°C): 28.89                  Wind Direction: SW  
 Intake Temp. (°C): 11.11                      Air Temp. (°C): 11.67

<u>Species</u>	<u>Total Number</u>	<u>Avg. Length (cm)</u>	<u>Avg. Weight (gm)</u>	<u>F/MG</u>
Rock Bass	3	20.9	201.3	0.01976
Yellow Perch	<u>4</u>	23.0	<u>194.5</u>	<u>0.02634</u>
Total	7		1381.9*	0.04610

\*Total weight of all impinged organisms

TABLE 34

Russell Power Plant  
1982 Impingement Program

Date: 10/20/82  
 Plant Flow (MGD): 158.26  
 Discharge Temp. (°C): 29.44  
 Intake Temp. (°C): 12.78  
 Wind Speed (knots): 12.52  
 Wind Direction: SW  
 Air Temp. (°C): 15.00

<u>Species</u>	<u>Total Number</u>	<u>Avg. Length (cm)</u>	<u>Avg. Weight (gm)</u>	<u>F/MG</u>
Rainbow Smelt Juv.	1	4.6	0.5	0.00632
Rock Bass	<u>1</u>	19.5	<u>174.0</u>	<u>0.00632</u>
Total	2		174.5*	0.01264

TABLE 35

Russell Power Plant  
1982 Impingement Program

Date: 10/26/82  
 Plant Flow (MGD): 151.85  
 Discharge Temp. (°C): 26.67  
 Intake Temp. (°C): 11.11  
 Wind Speed (knots): 4.34  
 Wind Direction: N  
 Air Temp. (°C): 7.22

<u>Species</u>	<u>Total Number</u>	<u>Avg. Length (cm)</u>	<u>Avg. Weight (gm)</u>	<u>F/MG</u>
Rainbow Smelt	1	13.4	12.0	0.00659
Yellow Perch	9	21.7	151.3	0.05927
Rock Bass	<u>15</u>	17.4	<u>121.3</u>	<u>0.09878</u>
Total	25		3193.2*	0.16464

\*Total weight of all impinged organisms

TABLE 36

Russell Power Plant  
1982 Impingement Program

Date: 11/02/82  
 Plant Flow (MGD): 151.85                      Wind Speed (knots): 8.34  
 Discharge Temp. ( $^{\circ}$ C): 26.67              Wind Direction: NW  
 Intake Temp. ( $^{\circ}$ C): 11.67                    Air Temp. ( $^{\circ}$ C): 13.33

<u>Species</u>	<u>Total Number</u>	<u>Avg. Length (cm)</u>	<u>Avg. Weight (gm)</u>	<u>F/MG</u>
Yellow Perch	2	20.0	115.5	0.01317
Rock Bass	<u>5</u>	18.4	<u>142.6</u>	<u>0.04610</u>
Total	7		944.0*	0.04610

TABLE 37

Russell Power Plant  
1982 Impingement Program

Date: 12/07/82  
 Plant Flow (MGD): 151.85                      Wind Speed (knots): 11.39  
 Discharge Temp. ( $^{\circ}$ C): 20.00              Wind Direction: W  
 Intake Temp. ( $^{\circ}$ C): 6.11                      Air Temp. ( $^{\circ}$ C): 4.44

<u>Species</u>	<u>Total Number</u>	<u>Avg. Length (cm)</u>	<u>Avg. Weight (gm)</u>	<u>F/MG</u>
White Perch	3	7.4	4.7	0.01976
Yellow Perch	<u>1</u>	18.7	<u>87.0</u>	<u>0.00659</u>
Total	4		101.1*	0.02634

\*Total weight of all impinged organisms

TABLE 38

Russell Power Plant  
1982 Impingement Program

Date: 12/16/82  
 Plant Flow (MGD): 139.39  
 Discharge Temp. (°C): 15.00  
 Intake Temp. (°C): 3.89  
 Wind Speed (knots): 12.52  
 Wind Direction: W  
 Air Temp. (°C): 3.89

<u>Species</u>	<u>Total Number</u>	<u>Avg. Length (cm)</u>	<u>Avg. Weight (gm)</u>	<u>F/MG</u>
Yellow Perch	1	18.0	72.0*	0.00717

TABLE 39

Russell Power Plant  
1982 Impingement Program

Date: 12/28/82  
 Plant Flow (MGD): 151.85  
 Discharge Temp. (°C): 18.33  
 Intake Temp. (°C): 5.00  
 Wind Speed (knots): 19.39  
 Wind Direction: W  
 Air Temp. (°C): 12.78

<u>Species</u>	<u>Total Number</u>	<u>Avg. Length (cm)</u>	<u>Avg. Weight (gm)</u>	<u>F/MG</u>
White Perch	1	24.8	305.0	0.00659
Yellow Perch	<u>2</u>	25.8	<u>250.5</u>	<u>0.01317</u>
Total	3		806.0*	0.01976

\*Total weight of all impinged organisms

TABLE 40

## Russell Power Station

## 1982 Impingement Program

## DAILY BIOMASS COLLECTIONS

January

DATE	WINDSPEED (KNOTS)	WIND DIRECTION	WATER TEMPERATURE (°C)	PLANT FLOW (MGD)	KG FISH	COMMENTS
1	15.91	NW	2.78	123.77	2.04	
2	8.78	NW	2.78	123.77	--	No Sample
3	9.21	SE	2.78	123.91	--	No Sample
4	17.21	SW	3.33	123.91	4.99	
5	16.52	W	2.78	123.91	1.59	
6	10.26	W	2.22	123.91	3.86	
7	12.60	W	2.78	123.91	1.59	
8	16.00	W	2.22	123.91	0.91	
9	14.34	W	1.67	123.91	0.57	
10	18.26	W	1.11	123.91	0.91	
11	19.91	SW	1.11	123.91	0.91	
12	4.86	SW	1.11	123.91	1.14	
13	7.39	SE	1.67	123.91	--	No Sample
14	6.60	N	1.11	123.91	2.38	
15	10.26	SW	1.11	123.91	14.76	
16	17.21	SW	1.11	123.91	--	No Sample
17	20.86	SW	1.11	123.91	4.99	
18	10.34	SW	1.11	123.91	1.93	
19	7.21	SE	1.11	123.91	0.59	Detailed Study
20	9.91	NE	1.67	123.91	1.36	
21	13.47	NE	0.56	123.91	2.95	
22	10.26	E	1.67	123.91	0.91	
23	20.60	SW	1.67	123.91	0.45	
24	25.04	SW	1.67	123.91	0.11	
25	12.00	SW	1.11	123.91	0.45	
26	10.00	NW	1.67	123.91	1.59	
27	8.34	S	1.67	123.91	0.57	
28	16.60	W	1.67	123.91	1.36	
29	12.17	W	1.11	123.91	2.10	Detailed Study
30	9.91	SW	1.11	127.62	0.79	
31	13.39	NE	0.56	127.87	0.45	

Total kg. = 56.25

TABLE 41

Russell Power Station  
1982 Impingement Program

## DAILY BIOMASS COLLECTIONS

February

DATE	WINDSPEED (KNOTS)	WIND DIRECTION	WATER TEMPERATURE (°C)	PLANT FLOW (MGD)	KG FISH	COMMENTS
1	17.39	SW	0.56	127.90	1.36	
2	5.91	S	0.56	127.90	0.00	No Fish
3	6.60	N	0.56	127.20	3.86	
4	11.73	NW	-0.56	132.20	0.68	
5	5.21	W	-0.56	90.70	4.77	
6	19.39	W	0.00	127.10	1.25	
7	17.13	SW	1.67	124.80	2.27	
8	13.47	W	1.67	118.90	2.04	
9	6.34	W	1.11	122.60	1.59	
10	15.21	W	1.11	124.20	1.70	
11	11.65	W	0.56	119.40	6.47	
12	8.17	W	0.56	127.70	2.76	Detailed Study
13	7.04	W	0.56	127.70	10.22	
14	6.34	SL	0.56	127.70	--	No Sample
15	13.39	W	0.56	127.70	1.59	
16	9.47	NE	0.56	127.90	2.27	
17	13.65	NE	0.56	127.90	2.50	
18	12.26	SE	0.56	127.00	--	No Sample
19	11.21	W	0.56	128.10	--	No Sample
20	8.00	NW	0.56	128.10	--	No Sample
21	8.86	NE	0.56	127.90	--	No Sample
22	10.52	NW	0.56	127.90	--	No Sample
23	12.17	W	0.56	127.90	1.36	
24	12.86	NE	0.52	127.70	3.18	
25	12.52	NW	1.11	127.70	2.27	
26	14.60	W	1.11	125.30	0.60	Detailed Study
27	7.91	W	1.11	124.90	0.91	
28	8.86	E	0.56	125.40	0.91	

Total kg. = 54.56

TABLE 42

## Russell Power Station

## 1982 Impingement Program

## DAILY BIOMASS COLLECTIONS

March

DATE	WINDSPEED (KNOTS)	WIND DIRECTION	WATER TEMPERATURE (°C)	PLANT FLOW (MGD)	KG FISH	COMMENTS
1	13.13	W	0.56	125.35	0.45	
2	12.17	W	1.11	125.35	3.63	
3	7.04	N	1.11	125.64	4.54	
4	11.04	S	0.00	132.19	3.63	
5	17.04	W	-0.56	132.19	0.54	Detailed Study
6	5.91	E	0.00	127.87	2.27	
7	9.91	NW	1.11	127.15	0.91	
8	11.21	NW	1.11	129.31	11.35	
9	15.65	W	0.56	117.00	6.81	
10	9.91	S	1.11	117.00	2.27	
11	10.17	SW	1.67	152.28	3.18	
12	6.34	SE	1.67	152.28	1.61	Detailed Study
13	20.34	W	1.67	152.28	1.36	
14	19.73	W	2.22	152.28	--	No Sample
15	6.78	E	2.22	152.28	0.91	
16	12.86	SE	2.22	152.28	11.35	
17	7.65	N	2.22	152.28	9.08	
18	4.78	W	2.22	152.28	2.27	
19	7.91	NW	2.22	152.28	--	No Sample
20	6.78	E	2.22	152.28	--	No Sample
21	14.78	W	2.22	152.28	1.82	
22	16.34	W	2.78	152.28	11.35	
23	7.91	NW	2.78	152.28	0.11	
24	6.86	W	3.33	152.06	7.95	
25	7.04	N	3.33	152.06	2.27	
26	17.65	W	2.78	152.06	--	No Sample
27	18.60	NW	2.22	152.06	4.34	Detailed Study
28	12.26	W	1.67	152.06	--	No Sample
29	7.91	W	1.67	152.28	4.54	
30	8.34	S	1.67	152.28	--	No Sample
31	17.21	SW	2.78	152.28	1.82	

Total Kg. = 100.36

TABLE 43

## Russell Power Station

1982 Impingement Program

## DAILY BIOMASS COLLECTIONS

April

DATE	WINDSPEED (KNOTS)	WIND DIRECTION	WATER TEMPERATURE (°C)	PLANT FLOW (MGD)	KG FISH	COMMENTS
1	20.34	NW	3.33	152.30	--	No Sample
2	9.73	NW	3.33	152.20	1.53	Detailed Study
3	18.34	SW	3.33	138.90	--	No Sample
4	23.47	NW	2.22	134.80	--	No Sample
5	12.17	NW	1.67	130.70	4.54	Heavy Debris
6	19.47	NE	2.78	155.30	11.80	Heavy Debris
7	19.47	NW	2.22	155.30	--	No Sample
8	13.21	W	1.67	155.30	1.50	
9	6.26	NW	2.22	155.30	--	No Sample
10	13.21	W	2.22	155.30	--	No Sample
11	10.78	W	3.33	155.30	0.23	
12	9.73	SE	2.78	155.30	1.82	
13	16.34	W	6.11	155.90	0.45	
14	9.13	NW	3.33	155.90	2.05	Detailed Study
15	5.21	S	3.89	155.90	1.70	
16	13.39	S	5.00	155.60	5.45	
17	17.65	W	5.00	155.60	4.31	
18	15.47	W	5.56	155.50	0.45	
19	8.60	SW	5.56	155.60	2.50	
20	7.21	W	6.67	155.60	--	No Sample
21	16.26	W	5.56	155.60	--	No Sample
22	13.13	W	5.00	155.60	4.77	
23	16.26	W	4.44	155.60	--	No Sample
24	15.13	SW	5.00	155.60	--	No Sample
25	8.52	SW	5.56	155.60	0.38	Detailed Study
26	5.21	NW	5.56	158.60	0.45	
27	9.91	NW	6.67	158.60	--	No Sample
28	11.04	NE	5.56	122.30	--	No Sample
29	5.65	NW	6.11	167.50	1.14	
30	7.39	N	6.67	157.50	0.68	

Total Kg. = 45.75

TABLE 44

## Russell Power Station

1982 Impingement Program

## DAILY BIOMASS COLLECTIONS

May

DATE	WINDSPEED (KNOTS)	WIND DIRECTION	WATER TEMPERATURE (°C)	PLANT FLOW (MGD)	KG FISH	COMMENTS
1	11.47	NW	6.67	157.54	--	No Sample
2	12.17	NW	6.67	157.54	--	No Sample
3	9.73	NW	7.78	157.54	--	No Sample
4	5.21	NE	7.22	157.54	0.00	No Fish
5	6.00	NE	6.67	157.54	0.00	No Fish
6	6.00	NW	6.67	157.54	0.00	No Fish
7	7.91	NW	6.67	157.54	0.00	No Fish
8	9.73	N	6.67	157.54	0.17	Detailed Study
9	11.39	N	7.22	157.39	0.00	No Fish
10	6.78	N	*	159.39	0.00	No Fish
11	5.04	W	7.22	157.54	--	No Sample
12	4.78	N	6.67	157.54	0.11	
13	4.00	NL	7.22	157.18	0.00	No Fish
14	5.04	NE	6.67	157.54	0.45	
15	4.60	NE	6.67	157.54	0.68	
16	6.60	NW	7.22	157.54	1.14	
17	6.60	NE	8.33	157.54	1.59	
18	4.26	NE	8.33	157.54	0.08	Detailed Study
19	8.17	W	7.78	157.18	0.11	
20	9.13	W	8.33	157.18	0.11	
21	9.47	NE	8.89	157.18	0.23	
22	9.39	SE	*	157.18	--	No Sample
23	10.60	SE	*	156.89	0.91	
24	5.21	N	6.67	157.18	1.36	
25	3.73	N	5.56	129.53	1.93	Detailed Study
26	5.04	NE	7.22	155.59	2.16	
27	5.39	SE	6.67	155.59	1.14	
28	10.34	SE	6.11	155.59	1.82	
29	5.39	SE	5.00	157.57	3.56	Detailed Study
30	5.73	N	4.44	118.22	2.72	
31	6.52	W	5.56	118.22	1.61	Detailed Study

Total Kg. = 21.88

\*Read not available

TABLE 45

## Russell Power Station

1982 Impingement Program

## DAILY BIOMASS COLLECTIONS

June

DATE	WINDSPEED (KNOTS)	WIND DIRECTION	WATER TEMPERATURE (°C)	PLANT FLOW (MGD)	KG FISH	COMMENTS
1	9.65	SW	5.56	118.22	1.82	
2	9.65	W	6.67	76.75	0.91	
3	7.21	NE	6.67	90.57	0.23	
4	7.04	SE	6.67	118.22	--	No Sample
5	10.52	NE	6.11	118.22	--	No Sample
6	12.52	NE	6.11	118.22	--	No Sample
7	6.17	NE	6.11	118.22	3.41	
8	5.39	NE	5.55	118.22	4.22	Detailed Study
9	5.73	NE	6.11	118.22	0.68	
10	10.86	S	5.55	118.22	0.68	
11	7.91	N	6.11	118.22	2.04	
12	6.17	S	6.11	118.22	0.68	
13	8.00	W	5.00	118.22	1.82	
14	7.73	W	5.55	118.22	1.14	
15	9.04	W	6.67	118.22	0.91	Detailed Study
16	9.04	W	8.89	118.22	1.14	
17	9.21	W	10.56	118.22	0.68	
18	5.91	N	10.56	118.22	0.68	
19	8.86	NW	10.56	118.22	0.68	
20	9.73	W	10.00	118.22	2.04	
21	11.91	SW	11.67	118.22	3.97	
22	5.73	SW	11.67	118.22	0.65	Detailed Study
23	10.78	W	12.22	118.22	2.50	
24	6.86	W	12.22	118.22	1.48	
25	10.00	W	13.33	118.22	1.93	
26	5.65	NE	12.78	118.22	1.14	
27	4.26	N	12.78	118.22	0.23	
28	5.21	NE	11.67	118.22	3.06	
29	5.39	NW	12.22	118.22	1.86	Detailed Study
30	10.26	NW	14.44	140.84	1.70	

Total Kg. = 42.28

TABLE 46

## Russell Power Station

1982 Impingement Program

## DAILY BIOMASS COLLECTIONS

July

DATE	WINDSPEED (KNOTS)	WIND DIRECTION	WATER TEMPERATURE (°C)	PLANT FLOW (MGD)	KG FISH	COMMENTS
1	8.60	NW	16.11	158.40	--	No Sample
2	13.21	W	16.11	158.40	--	No Sample
3	5.65	NE	15.00	123.12	0.34	
4	3.91	NE	13.89	107.57	2.50	
5	5.47	SW	13.33	132.19	3.18	
6	1.30	SW	13.89	167.47	4.54	
7	11.21	W	12.78	154.80	2.04	
8	10.26	W	17.22	154.80	2.27	
9	7.21	W	18.89	133.78	3.63	
10	6.26	E	18.89	93.17	3.18	
11	11.91	S	12.22	76.75	3.63	
12	13.47	SW	12.22	126.00	1.36	
13	5.91	N	17.78	126.00	2.52	Detailed Study
14	5.73	NE	17.78	126.00	1.25	
15	5.65	NE	17.78	126.00	1.02	
16	4.60	NE	17.78	126.00	7.72	
17	8.86	SW	16.67	126.00	--	No Sample
18	10.52	W	18.33	126.00	--	No Sample
19	8.52	NW	21.11	126.00	1.93	
20	5.73	NE	20.56	126.00	3.63	
21	5.21	N	20.56	126.00	5.90	
22	5.21	N	21.11	126.00	4.31	
23	6.60	NE	21.67	126.00	6.46	Detailed Study
24	5.21	NE	21.67	126.00	4.54	
25	9.73	W	17.78	126.00	2.04	
26	8.78	NW	20.56	126.00	1.59	
27	6.26	NE	21.67	126.00	5.45	Detailed Study
28	8.48	NW	21.11	126.00	2.16	
29	8.48	NW	21.11	126.00	1.59	
30	6.78	S	20.56	126.00	2.27	
31	9.73	W	17.22	126.00	1.82	

Total Kg. = 82.87

TABLE 47

## Russell Power Station

## 1982 Impingement Program

## DAILY BIOMASS COLLECTIONS

August

DATE	WINDSPEED (KNOTS)	WIND DIRECTION	WATER TEMPERATURE (°C)	PLANT FLOW (MGD)	KG FISH	COMMENTS
1	8.34	W	20.56	126.00	0.91	
2	7.21	N	20.56	126.00	2.72	
3	5.39	NE	20.56	126.00	0.00	No Fish
4	5.73	W	15.00	126.00	0.00	No Fish
5	6.34	N	16.67	126.00	1.36	
6	3.73	NE	16.67	126.00	0.68	
7	3.65	NE	15.00	126.00	0.45	
8	7.21	W	12.78	126.00	3.41	
9	9.47	W	10.56	126.00	8.17	
10	8.78	W	13.33	126.00	0.77	Detailed Study
11	7.04	W	20.00	132.91	1.25	
12	6.00	N	21.11	154.66	1.59	
13	4.34	NW	21.11	154.80	0.91	
14	6.52	NW	21.11	134.06	--	No Sample
15	4.86	NE	22.22	134.06	2.50	
16	6.34	W	21.67	134.06	0.68	
17	10.52	NW	21.67	133.55	0.49	Detailed Study
18	6.34	W	21.67	167.45	0.91	
19	11.13	W	21.67	153.22	4.19	
20	11.47	NW	21.11	153.22	0.23	
21	8.00	NW	*	120.96	0.91	
22	7.73	SW	*	120.96	--	No Sample
23	8.60	SW	*	120.96	0.23	
24	6.86	SW	20.00	120.96	0.04	Detailed Study
25	12.17	NW	20.00	120.96	2.95	
26	9.21	W	19.44	120.96	0.23	
27	10.34	NW	18.89	120.96	0.23	
28	10.17	NW	18.33	120.96	0.00	
29	7.91	W	17.78	120.96	0.00	
30	7.91	SW	17.78	71.71	0.68	
31	6.52	NE	18.89	119.16	0.00	Detailed Study

Total Kg. = 36.49

\*Read not available

TABLE 48

## Russell Power Station

1982 Impingement Program

## DAILY BIOMASS COLLECTIONS

September

DATE	WINDSPEED (KNOTS)	WIND DIRECTION	WATER TEMPERATURE (°C)	PLANT FLOW (MGD)	KG FISH	COMMENTS
1	7.73	SW	17.78	119.16	0.34	
2	10.00	W	16.67	118.73	0.45	
3	12.26	W	0.00	84.46	0.23	
4	9.04	NW	16.11	84.46	0.34	
5	7.04	W	16.11	84.46	0.11	
6	10.17	N	15.00	96.21	0.34	
7	9.39	E	16.67	119.74	1.59	
8	4.78	NW	15.56	118.73	1.16	Detailed Study
9	6.00	W	14.44	118.73	0.68	
10	5.65	W	15.56	119.74	0.11	
11	4.00	SW	15.56	119.74	1.36	
12	4.34	NE	15.00	119.74	0.79	
13	6.17	SW	14.44	119.74	0.68	
14	6.60	SE	12.22	119.74	0.20	Detailed Study
15	9.04	NE	13.89	119.74	2.84	
16	8.34	NW	12.22	119.74	0.91	
17	7.39	N	15.00	119.74	0.68	
18	11.04	NW	15.00	119.74	--	No Sample
19	6.17	NE	15.00	119.74	4.09	
20	6.52	W	15.56	119.74	0.68	
21	5.73	NE	16.11	119.74	--	No Sample
22	6.17	E	16.11	159.41	3.41	
23	8.86	W	15.00	94.41	4.09	
24	8.00	NE	15.00	151.85	1.59	
25	4.86	N	15.56	151.85	1.82	
26	4.17	SE	15.00	151.85	1.59	
27	7.73	N	15.00	158.26	1.59	
28	6.00	N	15.00	158.26	1.14	
29	5.21	N	15.56	117.94	1.36	
30	5.47	SW	14.44	117.94	0.23	

Total Kg. = 34.40

TABLE 49

## Russell Power Station

1982 Impingement Program

## DAILY BIOMASS COLLECTIONS

October

DATE	WINDSPEED (KNOTS)	WIND DIRECTION	WATER TEMPERATURE (°C)	PLANT FLOW (MGD)	KG FISH	COMMENTS
1	9.91	W	13.89	117.94	1.10	Detailed Study
2	6.34	NE	14.44	117.94	0.91	
3	6.78	W	13.89	117.94	2.61	
4	5.04	N	15.00	117.94	2.51	Detailed Study
5	3.39	N	14.44	117.94	1.36	
6	3.65	E	13.89	159.41	1.76	Detailed Study
7	3.73	SW	13.89	159.41	1.02	
8	4.78	W	13.89	159.41	0.68	
9	7.39	NE	15.00	159.41	0.68	
10	7.04	SE	13.33	159.41	1.36	
11	6.34	S	10.00	159.41	3.63	
12	6.52	W	7.78	159.41	--	No Sample
13	5.39	W	9.44	159.41	--	No Sample
14	10.17	SW	11.11	151.85	0.45	
15	13.47	NW	11.67	151.85	1.38	Detailed Study
16	11.91	NW	11.67	151.85	1.59	
17	9.73	NW	12.22	151.85	1.14	
18	6.34	SW	12.22	158.26	6.36	
19	10.00	SW	11.67	158.26	--	No Sample
20	12.52	SW	12.78	158.26	--	No Sample
21	15.39	W	12.78	158.26	0.18	Detailed Study
22	7.21	NW	11.67	158.26	0.23	
23	8.26	NW	11.11	158.26	0.23	
24	5.04	N	11.67	158.26	0.45	
25	3.13	N	11.67	158.26	2.16	
26	4.34	N	11.11	151.85	--	No Sample
27	3.91	SW	11.67	151.85	3.19	
28	4.52	SW	11.11	151.85	2.27	
29	8.17	SW	11.11	151.85	--	No Sample
30	8.60	W	11.67	151.85	0.68	
31	6.26	W	11.67	140.90	0.23	

Total kg. = 38.16

TABLE 50

## Russell Power Station

1982 Impingement Program

## DAILY BIOMASS COLLECTIONS

November

DATE	WINDSPEED (KNOTS)	WIND DIRECTION	WATER TEMPERATURE (°C)	PLANT FLOW (MGD)	KG FISH	COMMENTS
1	6.26	NW	11.67	151.85	--	No Sample
2	8.34	NW	11.67	151.85	--	No Sample
3	6.78	W	12.22	151.85	0.94	Detailed Study
4	8.86	W	11.67	151.85	0.11	
5	14.17	W	11.11	151.85	0.34	
6	11.91	W	10.56	151.85	--	No Sample
7	11.47	SW	9.44	151.85	0.45	
8	14.26	W	9.44	151.85	0.79	
9	6.34	NW	9.44	151.85	0.68	
10	5.73	SE	9.44	151.85	--	No Sample
11	12.34	SW	10.00	151.85	0.91	
12	17.21	W	10.00	151.85	0.45	
13	14.17	W	10.00	151.85	--	No Sample
14	7.04	W	8.33	151.85	0.23	
15	14.17	NW	7.78	151.85	0.23	
16	7.91	S	7.22	151.85	--	No Sample
17	5.91	SW	7.22	151.85	--	No Sample
18	5.04	SE	7.22	151.85	--	No Sample
19	8.26	S	8.33	148.36	--	No Sample
20	13.73	SW	8.33	139.62	0.68	
21	10.60	S	7.78	146.31	0.45	
22	6.78	NE	7.22	152.93	0.91	
23	5.13	NW	7.22	152.93	--	No Sample
24	14.00	W	7.78	151.85	1.02	
25	10.17	W	6.67	151.85	--	No Sample
26	8.60	NW	6.11	151.85	--	No Sample
27	10.00	NW	5.56	151.85	0.23	
28	7.39	SW	5.56	151.85	0.58	
29	13.91	W	5.96	151.85	2.72	
30	7.73	W	5.56	151.85	1.14	

Total Kg. = 12.86

TABLE 51

## Russell Power Station

## 1982 Impingement Program

## DAILY BIOMASS COLLECTIONS

December

DATE	WINDSPEED (KNOTS)	WIND DIRECTION	WATER TEMPERATURE (°C)	PLANT FLOW (MGD)	KG FISH	COMMENTS
1	6.86	SW	5.56	151.85	1.02	
2	6.26	S	5.56	151.85	--	No Sample
3	10.86	SW	6.11	151.85	0.00	No Fish
4	8.86	SW	6.67	151.85	0.91	
5	8.78	SW	7.22	151.85	0.91	
6	13.91	SW	6.67	151.85	3.63	
7	11.39	W	6.11	151.85	--	No Sample
8	5.91	N	6.11	151.85	0.10	Detailed Study
9	11.47	N	5.00	151.85	--	No Sample
10	9.91	SW	4.44	151.85	--	No Sample
11	9.21	NW	3.89	151.85	0.45	
12	11.21	N	3.89	151.85	0.23	
13	7.73	SW	3.33	151.85	--	No Sample
14	10.52	SW	2.78	151.85	--	No Sample
15	8.00	SW	3.33	139.39	0.23	
16	12.52	W	3.89	139.39	0.00	No Fish
17	10.00	N	3.89	128.88	0.07	Detailed Study
18	8.26	SE	2.78	151.85	0.23	
19	10.00	S	3.33	151.85	0.45	
20	7.65	NW	3.33	151.85	2.04	
21	12.26	N	2.78	151.85	--	No Sample
22	7.13	SW	3.33	151.85	0.45	
23	8.26	SE	2.22	151.85	1.82	
24	9.65	SW	2.78	151.85	--	No Sample
25	12.60	SW	3.89	151.85	--	No Sample
26	15.21	NW	4.44	151.85	--	No Sample
27	5.13	SW	4.44	151.85	--	No Sample
28	19.39	W	5.00	151.85	--	No Sample
29	16.00	W	5.00	151.85	0.81	Detailed Study
30	12.52	W	3.89	151.85	--	No Sample
31	6.60	W	3.89	151.85	--	No Sample

Total Kg. = 13.35